



Two-Ply Roof-Fast System Application Instructions/ Self-Adhered Method

ENGLISH

IMPORTANT MESSAGE • PLEASE READ! Products must be applied properly. IKO assumes no responsibility for leaks or defects resulting from poor application or failure to properly prepare the surface to be roofed over, or failure to provide proper ventilation in accordance with minimum property standards requirements. Review all applicable building codes, minimum property standards, and requirements prior to applying these products. Use caution when stacking product on sloped roofs.

These instructions are for a two-ply application of Roof-Fast. If installing a single-ply application, please see the Single-Ply Roof-Fast Cap Application Instructions. Always read the full instructions before beginning.

INSTALLATION TIP: When working on hot days and/or in bright sunlight, allow the product to cool in the shade for a few minutes before removing the release film.

GENERAL INFORMATION:

- Minimum roof slope for all two-ply applications is 1/2:12 up to and including 2:12. For slopes over 2:12 please contact IKO.
- Product should be stored upright at room temperature in a clean, dry, well-ventilated area that is protected from the elements. Rolls that are improperly stored, or are stored for a prolonged period of time, may result in improper bonding of the product upon installation. Do not attempt to install rolls that do not exhibit an adequate bond upon application.
- Two-Ply Systems are required to have IKO Roof-Fast Cap applied the same day.
- Acceptable substrates are plywood or oriented strand board, concrete, and metal. See substrate requirements below for details.
- All substrates must be clean and dry; substrates should also be dust-free plywood or oriented strand board (OSB). 1/2" (12 mm) plywood is recommended. Mill or plank decks should be covered with a layer of 1/4" (6 mm) sheathing. Decks must be well-secured with minimal deflection. Secure all nails and screws to prevent the possibility of backing out. Loose fasteners should be replaced and relocated if necessary.
- Wood substrates are recommended to be primed with IKO's S.A.M. Adhesive primer or S.A.M. Adhesive LVC primer before the application of the IKO Roof-Fast membrane.
- Concrete/metal must be primed with IKO's S.A.M. Adhesive primer or S.A.M. Adhesive LVC primer before the application of the IKO Roof-Fast membrane.
- Substrate must provide continuous, uninterrupted support to the membrane with no gaps within the substrate.
- Apply self-adhering membranes only when the weather is dry; air, roof deck, and membrane temperatures are 50°F (10°C) or above.
- Ensure that the installation of IKO Roof-Fast membranes does not prevent or interfere with the ventilation of the existing construction. IKO Roof-Fast membranes have the properties of a vapor barrier, and if applied over attic spaces, it is necessary to ensure adequate and thorough ventilation to prevent condensation.
- After cutting any lengths of IKO Roof-Fast membrane, allow the product time to relax prior to installation.

TOOLS AND ACCESSORIES FOR INSTALLATION:

Roofing Nails · T-Square · Chalk Line · Hand Steel/Silicone Roller · 60-100 lb. (27-45 kg) Steel/Silicone Roller (optional) · Roofer's Cutting Tool/Hook Blade · Roofing Trowel · IKO S.A.M. Adhesive primer, IKO S.A.M. Adhesive LVC primer* · IKO AquaBarrier Mastic · IKO EdgeSeal · High-Grade Exterior Caulk

**Allow to dry per manufacturer installation instructions but no less than 30 minutes.*

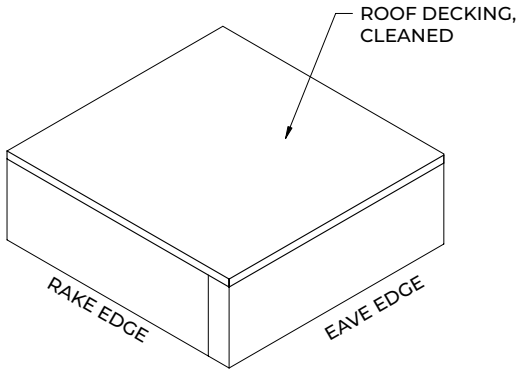

SUBSTRATE PREP

STEP 1: Surface Preparation

The roof deck must be clean, smooth, dry and free of sharp protrusions.

- For re-roofing, remove existing roofing material down to a satisfactory deck or acceptable, smooth primed surface. Plywood or OSB wood panel decking is to be exterior grade, conforming to building code requirements. 1/2" (12 mm) plywood is recommended. Mill or plank decks should be covered with a layer of 1/4" (6 mm) sheathing. Decks must be well-secured with minimal deflection. Secure all nails and screws to prevent the possibility of backing out. Loose fasteners should be replaced and relocated if necessary.
 - If the substrate surface is not flat, then voids may occur, which will result in installation difficulties. These installation difficulties could result in a roof that is not watertight.
- All Plywood or OSB wood panel substrates are recommended to be primed with IKO's S.A.M. Adhesive or S.A.M. Adhesive LVC before the application of the IKO Roof-Fast membrane.
- All substrates where Roof-Fast will be applied including concrete/metal must be primed with IKO's S.A.M. Adhesive or S.A.M. Adhesive LVC before the application of the IKO Roof-Fast membrane.
- Ensure all primed surfaces are completely dry before installation of Roof-Fast membrane. (Allow to dry per manufacturers' installation instructions but no less than 30 minutes.)
- Do not apply Roof-Fast to shingles. For steep slope tie-in see instructions within.

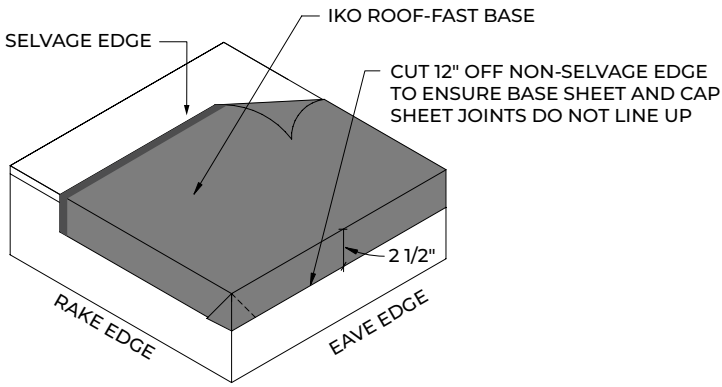

ROOF FAST BASE INSTALLATION

STEP 2: Roof-Fast Base

NOTE: Always start installation at the lowest point of the roof.

- Cut an appropriate length of IKO Roof-Fast Base for the eave ensuring enough material to cover the rake edges with 2 1/2" (64 mm) of material. Allow the material to relax.
 - *The starter strip assumes that the horizontal drip edge metal flange will be 3" (76 mm) wide, and the vertical face of the edge metal will be a 2 1/2" (64 mm) length with a minimum 1/2" (12 mm) 30-degree bevel at the lowest edge to divert water away from the building.*
- Cut 12" (305 mm) off, opposite the selvage edge, the IKO Roof-Fast Base lengthwise and dry fit to allow an overhang of 2 1/2" (64 mm) on the eave and rake edges.
- While holding the base layer in place, carefully remove the release film from the underside starting at one rake edge and continuing to the opposite rake edge. You should now have a 2 1/2" (64 mm) overhang on rake edges and eave.
- Cut from the intersecting corner (rake/eave) out to the edge of the sheet so that you have a 45-degree cut on both rake and eave edge.
- Apply the rake edges first and fold the 45-degree onto the eave edge fascia.
- Apply the eave edge last and fold the 45-degree onto the rake edge fascia.
- Use a roller overall all areas the IKO Roof-Fast Base has been applied to ensure consistent contact to the roof deck areas.

- Cut an appropriate length of IKO Roof-Fast Base for the next course ensuring enough material to cover the rake edges with 2 1/2" (64 mm) of material. Allow the material to relax.
- Dry fit the full sheet using the 3" (76 mm) selvage edge area on the already applied half sheet as a guide. Side laps should be a minimum of 3" (76 mm).
- While kneeling on the upper half of the positioned base sheet, fold back the lower half of the width towards you to expose the release film.
- Remove the selvage edge film release from the Roof-Fast Base, already applied to the roof deck.
- Remove the release film from the Roof-Fast Base and slowly "walk" the sheet into place.
- While kneeling on the lower half of the base sheet, fold back the upper half of the width towards you to expose the remaining release film. Remove the release film and slowly "walk" the upper half sheet into place.
- Use a 60-100 lb. (27-45 kg) steel roller, or hand roller, over the entire sheet of the IKO Roof-Fast Base to ensure consistent contact to the primed roof deck areas.
- Repeat all steps until the entire roof deck is covered with IKO Roof-Fast Base.

End Lap Joints

NOTE: There must be a minimum 24" (609 mm) from any other end laps or joints within the roof system. Specific to Roof-Fast Base a 2" (50 mm) 45-degree cut must be made at both top and bottom corners of the underlying sheet.

Application - Intersection of Rake-Edge Side Wall

NOTE: If your roof has no rake-edge side walls move to STEP 3. For existing construction, carefully remove the siding in the rake area(s). For new construction, complete the Roof-Fast application prior to application of siding in these areas.

- When cutting an appropriate length of IKO Roof-Fast Base to accommodate a rake-edge wall ensure to leave a minimum of 3" (76 mm) to go up the wall.
- It's best to end the course application at the rake-edge side wall ensuring you firmly press the base layer into the corner before applying it up the wall. This will ensure a good seal of any voids at this intersecting area.
- Use a roller to roll all areas the IKO Roof-Fast Base has been applied to ensure consistent contact.

Application – Residential Slope Tie-In

NOTE: If your roof has no residential steep slope tie-in, move to STEP 3.

- When finishing the base layer at a steep slope area you must ensure the base layer finishes a minimum of 15" (381 mm) up the steep slope.

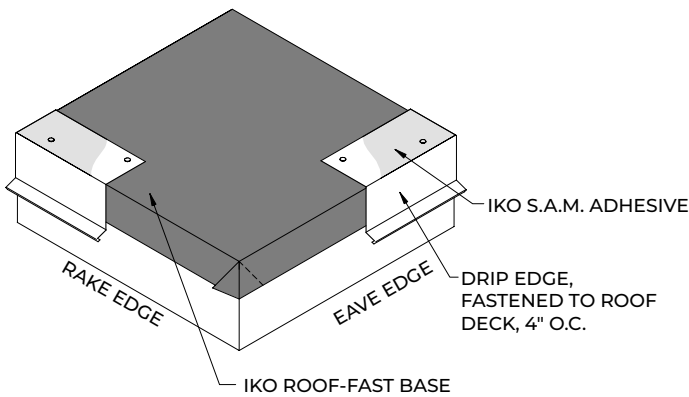

DRIP EDGE INSTALLATION

STEP 3: Drip Metal

- Prime the top side of the drip metal and allow it to dry as per the manufacturer's instructions, no less than 30 minutes.
- Install the eave drip edge over the IKO Roof-Fast Base and fasten 4" (102 mm) on-center staggered within 1" (25 mm) of the eave with roofing nails. Face fastening the drip metal is not recommended.
- Repeat STEP 3 for the rake edges ensuring special attention to the intersection with the eave drip edge metal.

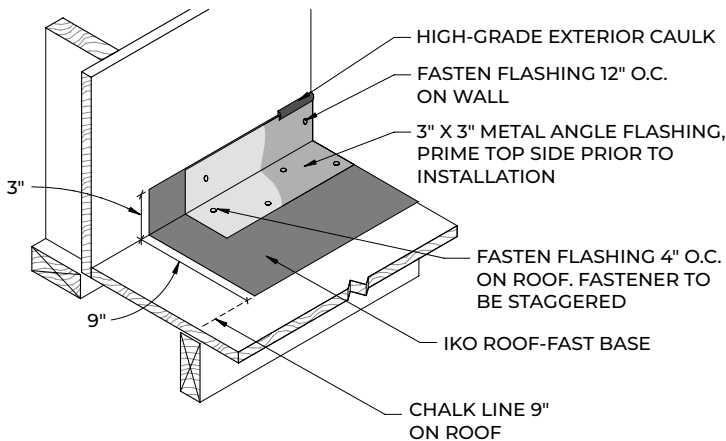

RAKE / WALL CONNECTION DETAIL

STEP 4a: Application - Intersection of Rake-Edge Side Wall

NOTE: If your roof has no rake-edge side walls move to STEP 5.

- Cut an appropriate length of the IKO Roof-Fast Base and cut the sheet lengthwise at 12" (305 mm) for starter strip.
 - *The starter strip assumes that the angle flashing will be 3" (76 mm) wide on either side of the 90-degree break in the metal.*
- Measure back 9" (229 mm) from the wall at the rake-edge side wall and snap a chalk line on the slope area.
- Using the chalk line as a guide, position the starter strip so that there is approximately 9" (229 mm) on the roof slope surface and 3" (76 mm) up the rake wall surface.

- Prime the top side of the angle flashing and allow to dry as per the manufacturer's instructions, no less than a minimum of 30 minutes.
- Install the angle flashing over the starter strip and fasten 4" (102 mm) on-center staggered on the roof slope surface and 12" (305 mm) on-center on the rake wall surface.
 - *Overlap successive sections of angle flashing with a minimum of 6" (152 mm).*

NOTE: Do not replace siding at this point as high-grade exterior caulking will need to be applied at intersections where Roof-Fast overlaps with the angle flashing.

STEP 4b: Application – Residential Slope Tie-In

NOTE: If your roof has no residential steep slope tie-in move to STEP 6.

- Measure up the steep slope, area to be shingled, and chalk a line at minimum 15" (381 mm) up the slope, and another at minimum 18" (457 mm) up the slope, a minimum of 3" (76 mm) past the first chalk line.
- The IKO Roof-Fast Base must end a minimum of 15" (381 mm) up the steep slope.
- The IKO Roof-Fast Cap must end a minimum of 18" (457 mm) up the steep slope, or 3" (76 mm) past the IKO Roof-Fast Base.

NOTE: Shingle application should start 2" (50 mm) up the steep slope area on IKO Roof-Fast Cap.

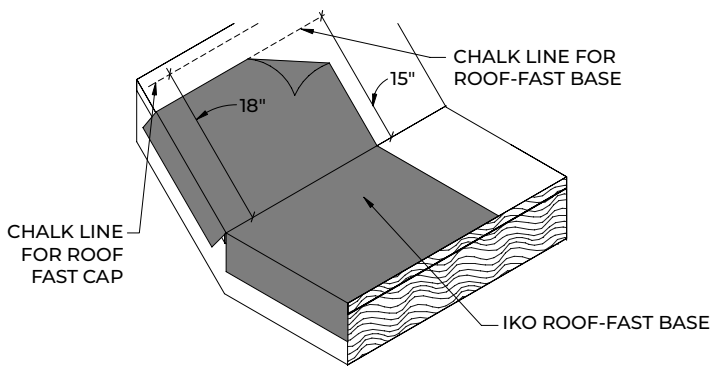

STEEP SLOPE CONNECTION

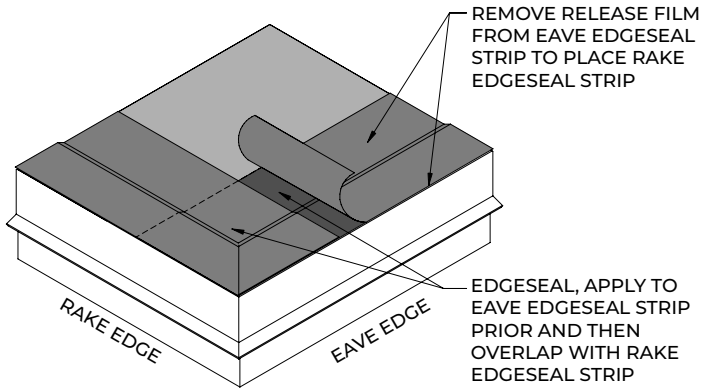

EDGESEAL INSTALLATION

STEP 5: Roof-Fast Cap Application Preparation

- Cut an appropriate length of IKO EdgeSeal starter strip for the eave. Dry fit this starter strip to fit flush with the drip metal at the eave and rake edges.
- Remove the release film on the underside of the IKO EdgeSeal starter strip and apply flush with the drip metal at the eave and rake edges.
- Repeat this process for the rake edges. When intersecting with the starter strip applied at the eave, peel back just enough of the release film on the eave and apply the rake edge starter over the eave starter. See EdgeSeal Installation diagram.
 - Repeat this process for an intersection of the rake-edge side wall.

STEP 6: Roof-Fast Cap Application

- Unroll and cut the Roof-Fast Cap to the appropriate length allowing for extra material for rake and slope side detail, and trim to the exact length during application. Allow product to relax.
 - *In hot weather, it may be best to limit the length of individual pieces of Roof-Fast Cap to 12' (3.66 m) for ease of handling.*
- Position and align the length of Roof-Fast Cap, granule side up, flush with the drip edge metal at the lowest part of the roof. Ensure the film-covered selvage edge is opposite the drip edge metal.
- While kneeling on the upper half of the positioned cap sheet, fold back the lower half of the width towards you to expose the release film.
- Remove the release film from the starter strip at eave and rake edges, then remove the release film from the Roof-Fast Cap and slowly “walk” the sheet into place over the starter strip.

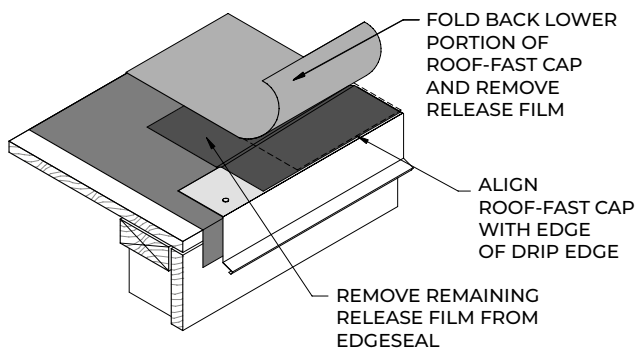

ROOF-FAST CAP INSTALLATION

- Only remove enough of the rake edge starter strip release film as necessary for the width of the sheet you are working with for each course.

NOTE: If there is a residential steep-slope tie-in, ensure the Roof-Fast cap extends up the slope a minimum of 18" (457 mm) and is applied to a primed surface.

- While kneeling on the lower half of the cap sheet, fold back the upper half of the width towards you to expose the remaining release film. Remove the release film and slowly “walk” the upper half sheet into place.
- Use a 60-100 lb. (27-45 kg) steel roller, or hand roller, to ensure consistent contact of Roof-Fast Cap to the starter strip and Roof-Fast Base areas.
- Trim the Roof-Fast Cap at rake edges to be flush with drip edge metal and rake-edge side walls to be flush with the inside corner of L-shaped edge metal.
- For installation of successive courses, again unroll and cut the Roof-Fast Cap to the appropriate length, position and align the length of Roof-Fast Cap, granule side up, ensuring complete coverage of the 3" (76 mm) selvage edge.
- While kneeling on the upper half of the positioned cap sheet, fold back the lower half of the width towards you to expose the release film.
- Remove the release film from the selvage edge, then remove the release film from the Roof-Fast Cap and slowly “walk” the sheet into place over the selvage edge.
 - It's best to remove an equal length of release film from the selvage edge as the length of the Roof-Fast Cap that you are working with.
- Repeat STEP 6 until the roof is complete.

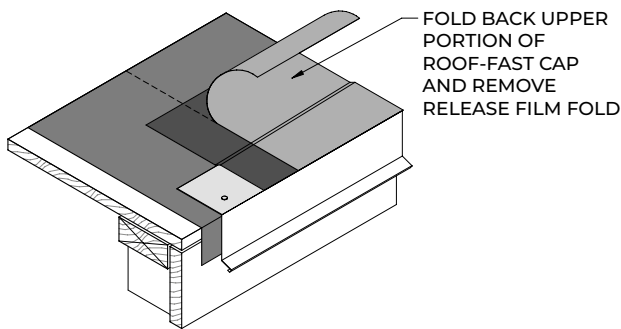

ROOF-FAST CAP INSTALLATION

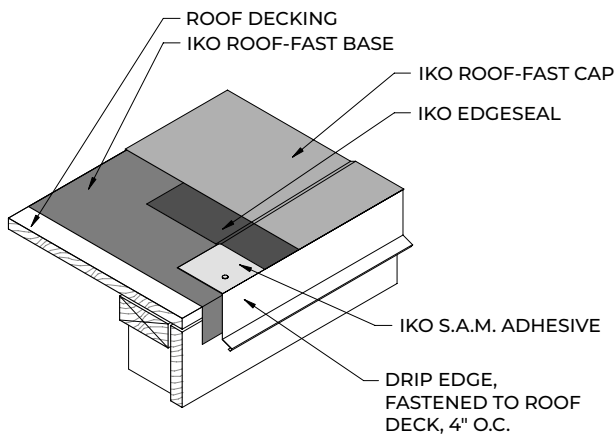

TWO-PLY ROOF-FAST SA APPLICATION - COMBINED

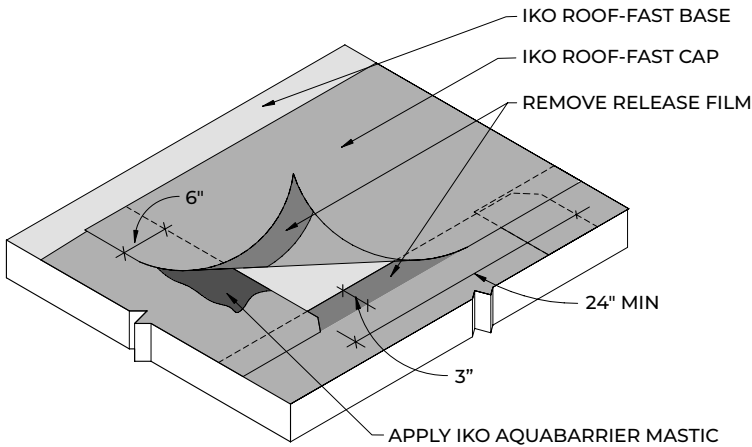

END LAP DETAIL

End Lap Joints

NOTE: There must be a minimum 24" (609 mm) from any other end laps or joints within the roof system. Specific to Roof-Fast Cap, if an end lap (vertical lap) joint must be made, a 2" (50 mm) 45-degree cut must be made at the top corner of the top sheet where the joint is made, and at the bottom of the bottom sheet where the joint is made.

After applying the first section of the successive course base sheet, unroll and cut the Roof-Fast Base to the appropriate length ensuring a minimum 6" (152 mm) end lap. Roof-Fast Cap follows this same procedure where necessary.

- Position and align the length of Roof-Fast Base, release film side down, ensuring complete coverage of the 3" (76 mm) selvage edge and the 6" (152 mm) end lap. Roof-Fast Cap follows this same procedure where necessary.
- For Roof-Fast Base only, remove the release film and roll the end lap over the set base sheet.
- Use a hand roller to apply uniform even pressure paying special attention to the joint area.
 - This only applies to Roof-Fast Cap sheet. Roll the end lap area towards you and apply a 6" (152 mm) wide x 1/8" (3 mm) thick band of IKO AquaBarrier Mastic, to the granule surface of the set granulated cap sheet.
 - Remove the release film and roll the end lap over the mastic area.
 - Use a hand roller to apply uniform even pressure paying special attention to the joint area and ensure a 1/4" (6 mm) bleed out of mastic is exposed.